



> MULTIJET COMPACT

An extremely sturdy and reliable self-service high-pressure washing station for motor vehicles and bicycles. Easy-to-use, it has seven washing programmes, which guarantees the highest quality and safety standards.

IDEAL FOR:

- » Washing vehicles at service stations;
- » Car wash stations;
- » Private fleet washing stations.

EQUIPMENT

This machine has 2 main components: the control terminals and the technical cabinet.

CONTROL TERMINALS

It contains an electronic acceptor of 3 different coins + 1 token, with a coin drawer in AISI 304 welded 1.5-mm stainless steel plate with a Securital KYR lock, retroilluminated alphanumeric display (showing the remaining credit information, the current wash programme and total), a touch-sensitive piezoelectric control keypad for selecting wash programmes and an emergency stop push button.

TECHNICAL CABINET

All the mechanical, electrical and electronic components of the equipment come inside the technical cabinet: -Water treatment systems (Cintropur NW25 1" water inlet filter, duplex decalcifier, dechlorinator, multi-media filter, reverse osmosis, treated water accumulation deposit); -Air compressor; -Water heating unit; -High-pressure motor pump units; -Dosing pumps for chemical washing products; -Differential pressure switch (which avoids dry operation); -Anti-freeze system for equipment protection; -Electric panel with general cut-off switch and integrated key lock push button switch for programming prices.

✓ TECHNICAL SPECIFICATIONS

PERFORMANCE	
Programmes: pre-wash (low or high pressure), shampoo wash, foam wash, rinsing, wax, finish and rim wash.	
Maximum pressure	100 bar
Operating pressure (recommended)	90 bar
Maximum flow rate	8 l/min
Detergent tanks	up to 25 Litres

TECHNICAL CABINET DIMENSIONS	
Height	2380 mm
Depth	1088 mm
Length	5760 mm
Weight	2000 Kg

ELECTRICAL FEATURES	
Supply voltage	380/400 V (3-)+ Neutral
Control voltage	24 Vdc /220 V (a.c.)
Maximum current	21 A (1 box); 28 A (2 boxes); 35 A (3 boxes); 42 A (4 boxes)
Installed power	8 KVA (1 box); 11 KVA (2 boxes); 14 KVA (3 boxes); 17 KVA (4 boxes)
Power cable	4x4+T4 mm ²
For distances over 50 m, resize the power cord.	

WATER SUPPLY SPECIFICATIONS			
No. of boxes	Minimum inner diameter	Minimum flow (m ³ /h)	Minimum pressure (Bar)
1	1"	4	4
2			
3	1"	5.5	5
4			

ENVIRONMENTAL SERVICE FEATURES	
Relative humidity	5 to 95%
Maximum temperature	60°C
Minimum temperature (standard)	0°C*

CONSUMPTION BY PROGRAMME AND WASHING BOX										
No.	Programme Description	Hot water (l/min)	Treated water (l/min)	Osmotic water (l/min)	Pre-wash product (ml/min)	Shampoo (ml/min)	Wax (ml/min)	Rim wash (ml/min)	Electric. kWh	Diesel (l/h)
1.1	Pre-wash (low pressure)	3	-	-	15 ¹	-	-	-	2.7	0.9
1.2	Pre-wash (high pressure)	8	-	-	15 ¹	-	-	-	2.7	0.9
2	Washing with shampoo	8	-	-	-	10 ¹	-	-	2.7	0.9
3	Washing with foam	8	-	-	-	10 ¹	-	-	2.7	0.9
4	Rinsing	-	8	-	-	-	-	-	2.7	
5	Wax	-	-	3	-	-	5 ¹	-	3.2	
6	Finish	-	-	8	-	-	-	-	3.5	
7	Rim wash	-	0.3	-	-	-	-	60 ¹	3.1	

¹ Recommended values. Must be adjusted to the local operating conditions and the intended wash quality.

ANTI-FREEZE SYSTEM	
The basic anti-freeze system is available for this equipment (recommended for minimum temperatures of -5°C, which will shut down the equipment below 0°C)	

OPTIONS	
-Rim wash programme; -Pre-wash programme; -Foam programme; -Reverse osmosis system; -Dechlorinating vs multimedia filter; -External water deposit; -360° single (or double) rotating arm in AISI 304 stainless steel; -Arm brackets; -PH correction system; -Anti-freeze system; -Water flow meter; -Personalised image; -Roof; -LED roof lighting; -Printer terminal; -Bicycle wash grid; -Standalone control console; -Control terminal sun visor; -Electrical protection (overvoltage); -Colour; -Electric boiler.	

✓ TECHNICAL DRAWINGS

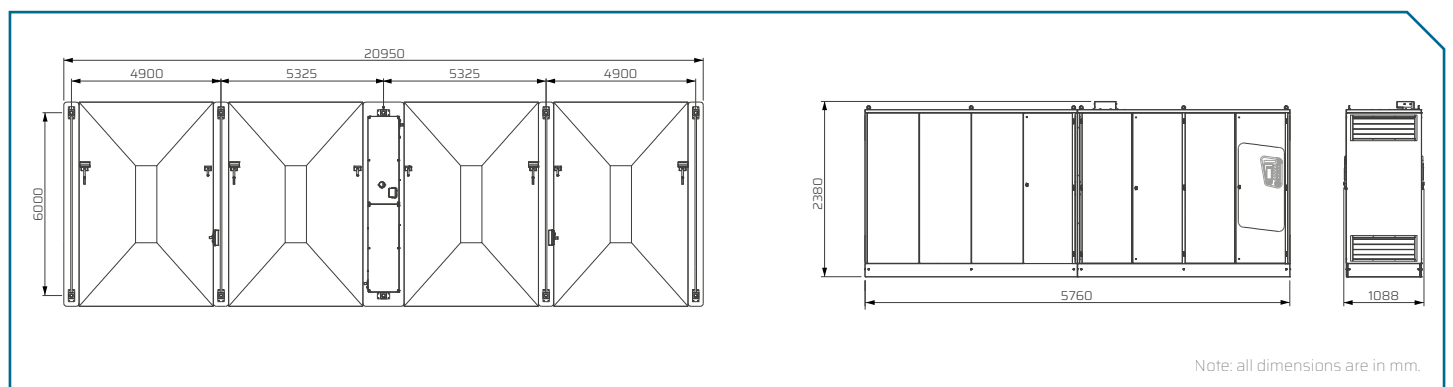

© 2019 Petrotec Group | All rights reserved. Petrotec, the Petrotec logo, Progress and combinations thereof are registered trademarks of Petrotec Group. Other names are informational and may be trademarks of their respective owners. Petrotec is continuously improving its products. Changes on the specifications may occur without prior notice. The imagery used may be indicative of style only. The available brochures are a guide and do not constitute an offer or contract.

